

SONY®

Video Communication System

PCS-G50

PCS-G50P



IPELA™

INTEGRATED VISUAL COMMUNICATION

IPELA

IPELA is Sony's vision of the ultimate workplace, designed to revolutionize the way business communicates over global IP networks. Utilizing Sony's line of high quality, IP-ready videoconferencing and monitoring products, communication is delivered in high-resolution images and naturally clear audio – with a quality never before achieved.

Sony PCS-G50*1 – The Business Tool for Visual Communication

To stay ahead of the pack in today's tough market, businesses require powerful visual communication tools like the PCS-G50. Sony has combined advanced audio and video technologies with useful features to provide a visual communication tool for all businesses. With the PCS-G50, long distance meetings can be held as if all parties were in the same room, saving the time and trouble of traveling to distant locations for a simple meeting. Providing you with a new and powerful means of communication, the PCS-G50 will be a mainstay for your business.

The PCS-G50 boasts a maximum video transfer rate of 4 Mb/s over an IP network, and it provides extremely high resolution video. By adopting the H.263 video codec/4CIF format, the PCS-G50 produces image resolution comparable to that of standard TV broadcasts. It can also switch to the H.264 video codec for higher throughput or revert to previous versions of the ITU-T videoconferencing codecs to maintain compatibility with legacy systems.

As with other PCS Series models, the PCS-G50, with its internal MCU (Multi-Control Unit) capability, supports simultaneous multi-point videoconferences with six (6) endpoints, and a maximum of 10 endpoints when two PCS-G50 units are cascaded. The PCS-G50 bridges mixed calls between an ISDN network and an IP network, and speed matches (by connecting at the endpoint respective speeds) without lowering the performance of the entire system.

Other key features of the PCS-G50 include a site-name display function and the capability to record audio and video to Memory Stick® media. The PCS-G50 also incorporates features such as data sharing, QoS support functions, an encryption function, and digital whiteboard support, which are all available in other PCS Series models.

Effective visual communication is vital to move ahead in today's business. With the feature-rich PCS-G50, not only will your visual communication be effective, it will be affordable.

*1 Unless otherwise noted, "PCS-G50" in the following text refers to both the PCS-G50 and PCS-G50P.



Simulated images

FEATURES

High-Quality Video/High-Speed Network Connection

The PCS-G50 provides excellent picture quality over both ISDN (H.320) and IP (H.323) networks and fully supports the latest non-proprietary ITU-T H.264 video codec standard for maximum customer confidence and flexibility. When video encoding is in accordance with the H.263 protocol, the PCS-G50 supports the 4CIF format at a maximum frame rate of 30 fps, and when in H.264 protocol, it supports the interlaced SIF format at 60 fields per second.^{*2} In addition, the PCS-G50 can achieve a maximum bandwidth of 4 Mb/s with an IP connection, and up to 768 Kb/s with an ISDN connection using an optional PCSA-B768S ISDN unit. This combination of high-quality codec and high-speed network support provides video quality comparable to standard TV broadcasts.

^{*2} The PCS-G50P supports a maximum of 50 fields per second in interlaced SIF format.

Multi-Point Videoconferencing at up to 10 Sites *Fig 1*

Using optional MCU software, the PCS-G50 can be configured to communicate with up to 5 remote videoconferencing sites (6 sites total) simultaneously using either an IP (H.323 protocol) or ISDN (H.320 protocol) connection. It can also support videoconferences in which the connections are a combination of IP and ISDN using a unique bridging function. And because the PCS-G50 has a "speedmatching" function, it maximizes performance by not reducing the higher speed connection to match the lower speed connection, as is done with some videoconferencing systems. Moreover, two PCS-G50 units - each installed with the optional MCU (H.323) software - can be cascaded with an IP connection to support a maximum of 10 simultaneous sites. What is unique about the PCS-G50 is that it provides high quality, H.264 CIF video and clear MPEG-4 AAC audio, even in a multi-point videoconference. And of course, the PCS-G50 allows users to expand from a peer-to-peer videoconference to a multi-point videoconference by simply dialing up new connections.^{*3}

^{*3} When adding a new endpoint on the same network (IP or ISDN), the system will default to the lowest resolution video standard of all endpoints.

Site-Name Display *Fig 2*

During multi-point videoconferences, it can be difficult to keep track of all of the participants; however, with the PCS-G50 site-name display function, this is no longer the case. The PCS-G50 can display anything from company or branch names to geographical locations on a monitor, allowing videoconference participants to keep track of all parties.

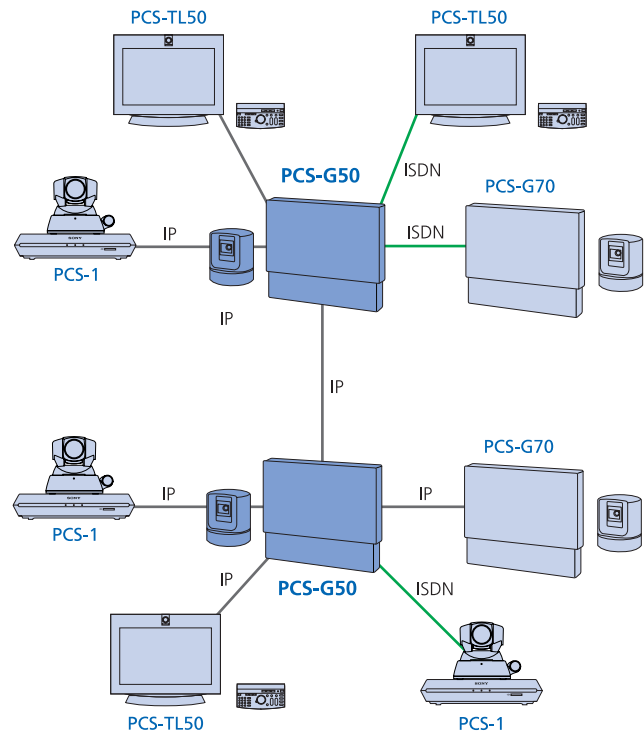

Fig 1 Multi-point Videoconferencing at up to 10 Sites



Fig 2 Site-Name Display

Simulated image

Flexible Display Patterns at all Sites

In addition to conventional patterns of display – such as showing the far-end site on a full screen or displaying near-end and far-end sites in picture-in-picture mode – a variety of other display patterns are available with the PCS-G50. Supporting both 4-screen and 6-screen continuous-presence modes, the PCS-G50 can display the most appropriate pattern to match the number of sites that are connected. In both full-screen and continuous-presence modes, the following two display options are available:

Voice Switching

The PCS-G50 defaults to voice switching, which displays the far-end site that is actively talking on the monitor when the unit is in full-screen mode. In continuous-presence mode, the site that is actively speaking is displayed on the largest of the six sub screens, and the near-end site is displayed on the sub screen where the original far-end site was.

Fixed Site *Fig 3*

As its name suggests, the selected far-end site is continuously displayed on the monitor when the unit is in full-screen mode. In continuous-presence mode the selected far-end site is displayed in the largest of the six sub screens, and the other sites are fixed as well.

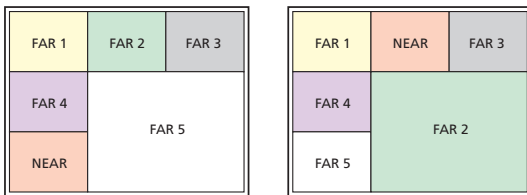

Fig 3 Voice Switching in Continuous Presence Mode

Audiovisual (A/V) Recording to Memory Stick Media

Capturing audio and video during a videoconference is important to keep a record of what was conveyed during a conference. With the PCS-G50, audio and video displayed on the main monitor can be recorded^{*4} directly to Memory Stick media in MPEG-4 format and can be played back on any PC using QuickTime® media player.

^{*4} AV recording is not supported when AES is active. Also, graphical data cannot be recorded.

Data-Sharing Capabilities/Digital Whiteboard Support

Data originated on your PC can be shared with your videoconferencing counterparts, making communication even more effective. Any image that can be displayed on a PC can be sent or received^{*5} in native XGA resolution, allowing all parties to share data during a videoconference. In addition, information drawn up on a digital whiteboard^{*6} can also be viewed in real time by all parties participating in a videoconference or captured and stored for later reference.

^{*5} Sending data requires the optional PCSA-DSB1S Data Solution Box (DSB); however, the DSB is not required for receiving data

^{*6} Please contact the nearest Sony sales office for information on compatible digital whiteboards.

Superb Sound *Fig 4*

The PCS-G50 reproduces clear and natural-sounding audio using MPEG-4 AAC (Advanced Audio Coding) at 14 KHz. A built-in echo cancellation system minimizes unwanted echoes during a videoconference.

The PCS-G50 works with a number of actual SONY external microphones and speakers, including unidirectional and omnidirectional models. Professional A/V integrators will particularly appreciate the power and flexibility of this system to be customized for best application match.

For exceptional sound quality in rooms with conference tables in a U-shape or in a classroom layout, the optional unidirectional PCSA-A7 microphone is ideal. Up to 40 units can be daisy chained so that all participants sitting near a microphone can be heard.

Stylish Design

With its elegant design and optional stands for both the camera unit and the codec unit, the PCS-G50 can fit into even the classiest of conference rooms.

Fig 4 Superb Sound

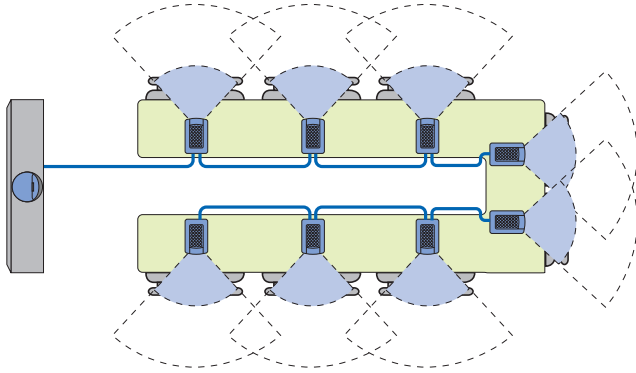

PCSA-A7 (U-Shaped Conference Table)

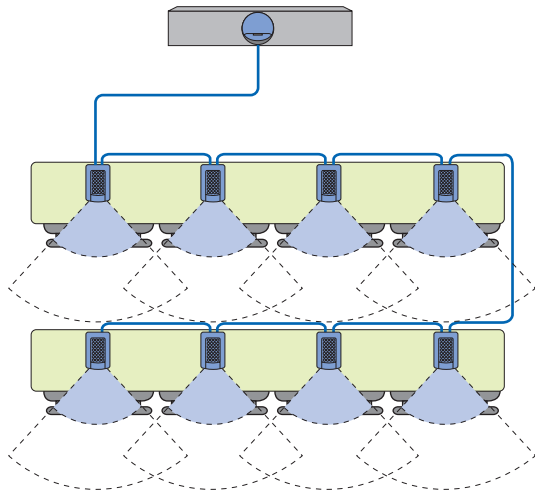

PCSA-A7 (Classroom Layout)

Easy-to-Use Remote Commander Unit/Intuitive GUI

The PCS-G50 has a number of features that make it easy to operate. The cursor keys on the Remote Commander® unit can be used to select and call any one of three contacts, which are pre-programmed and displayed in the Launcher Menu. Up to 500 contacts can be stored in the PCS-G50 common address book for quick and easy dialing. In addition, the unit supports a call history log, which stores the last 32 incoming and outgoing calls so that the user can readily select and dial a recent contact.



Remote Commander Unit



Launcher Menu

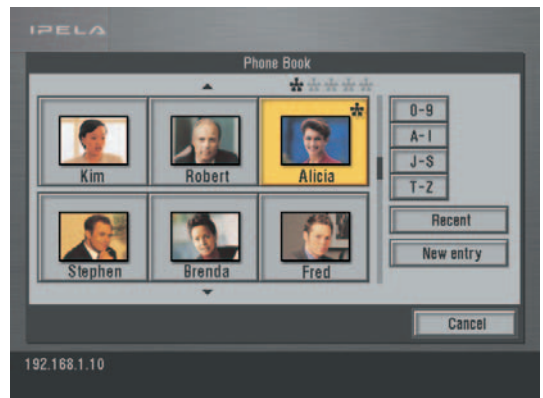

Phone Book

Simulated images

Memory Stick Media Support*7

Private phone books can be created and stored on Memory Stick media. By simply inserting the Memory Stick media into the PCS-G50, the unit automatically recognizes and activates the private phone book, thereby eliminating the need to re-enter contact information to place a call. Memory Stick media has a number of other uses, such as storing captured images, PC-generated data, and digital whiteboard drawings. The media can also be used for installing and updating software.

*7 In addition to Memory Stick media, Memory Stick PRO™ and Memory Stick DUO™ media with an adaptor can be used.

Secure Videoconferencing – Advanced Encryption Standard (AES)

Secure videoconferencing over a network is possible because the PCS-G50 supports AES Encryption, a NIST (National Institute of Standards and Technology) standard for encrypting electronic data used in commercial applications including telecommunications. When a videoconference is initiated with the AES feature active, video, audio, and graphics are encrypted for the duration of the videoconference. Because of this feature, companies can hold sensitive meetings, negotiations, and other similar interactions with confidence that they will not be compromised.

QoS (Quality of Service) Enhancement Functions

When holding a videoconference over a network, a common concern is how to maintain video and audio quality when the performance of the network is changing. The PCS-G50 provides three advanced functions to enhance QoS over a network:

Forward Error Correction (FEC)

The PCS-G50 employs an FEC function that corrects errors in transmission at the receiving end. If a transmission error occurs, the PCS-G50 can repair the data and accurately reproduce the original audio and video.

Adaptive Rate Control (ARC)

The adaptive rate control function automatically varies the video data transfer rate to meet changing network conditions. It also selects the most appropriate frame rates, which helps prevent audio and video breakup.

Real-time Auto Repeat Request (ARQ)

The real-time ARQ function recovers lost IP packets. This is achieved by buffering the packets at the encoder and resending any that are lost. This feature helps maintain audio and video quality, and helps prevent picture collapse even under high network traffic conditions.

SAMPLE SYSTEM CONFIGURATION

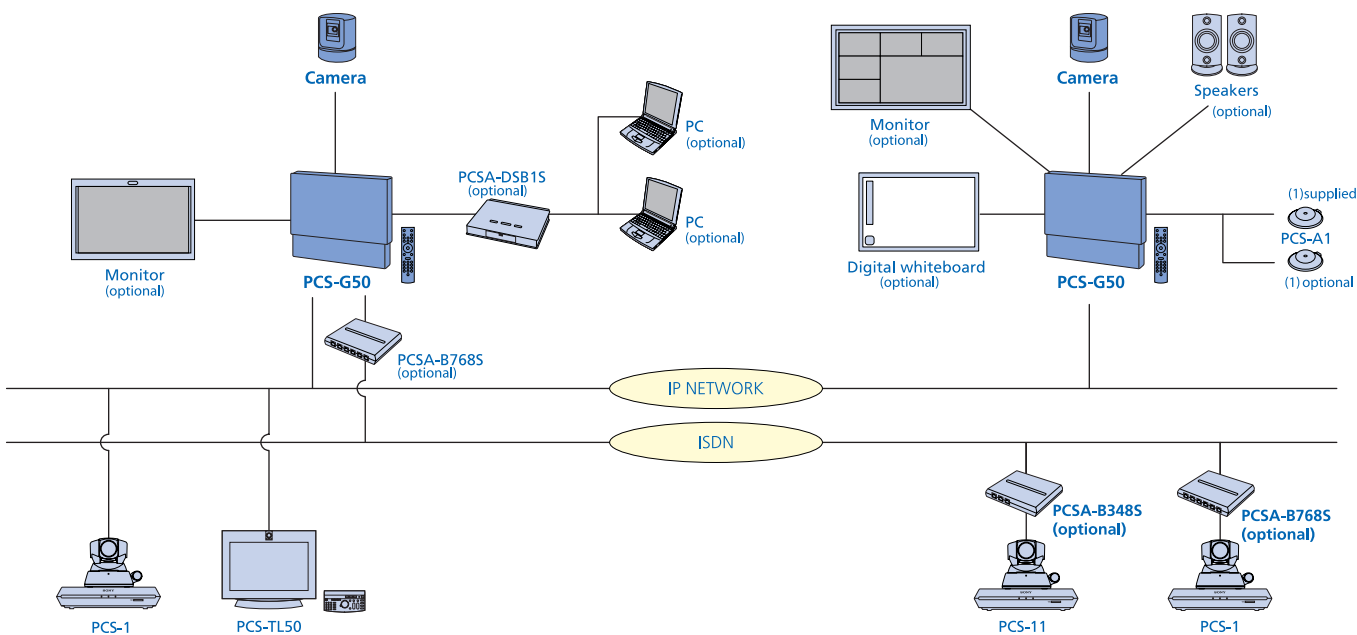

OPTIONAL ACCESSORIES



PCSA-DSB1S
Data Solution Box



PCSA-B768S
ISDN Unit (6 BRI)



PCSA-B384S
ISDN Unit (3 BRI)



PCSA-M0G50
H.320 MCU Software
PCSA-M3G50
H.323 MCU Software



PCSA-SP1
SIP Software



PCSA-A7
Echo-cancelling Microphone
(4 mics per package)



PCS-A1
Omnidirectional Microphone



PCSA-A3
Unidirectional Microphone



EVI-D70W / EVI-D70PW
Communication
Video Camera (white)



EVI-D70/EVI-D70P
Communication
Video Camera (black)



EVI-D100/EVI-D100P
Communication
Video Camera



PCSA-STMG70
Codec Stand



PCSA-STCG70
Camera Stand

SPECIFICATIONS

Video	
Signal system	PCS-G50: NTSC PCS-G50P: PAL
Standards	H.261 (Annex D), H.263 (Annex D,F), H.263+ (Annex J), H.263++ (Annex U,W), H.264, MPEG-4 SP@L3
Resolution	SQCIF (128 x 96, reception only), QCIF (176 x 144), CIF (352 x 288), 4CIF (704 x 576, H.263 only), Interlaced SIF (H.263, H.264 only)
Frame rate	Max. 30 frames/s (H.261, H.263, H.263+, H.263++, H.264, and MPEG-4 SP@L3) Interlaced SIF Mode (PCS-G50N: 60 fields/s, PCS-G50NP: 50 fields/s)
Bit rate	Up to 4 Mb/s in H.323 (Incl. audio)* Up to 768 Kb/s in H.320 (Incl. audio) when configured with the PCSA-B768S Up to 384 Kb/s in H.320 (Incl. audio) when configured with the PCSA-B384S

Audio	
Bandwidth and coding	G.711: 3.4 kHz at 56/64 Kb/s G.722: 7.0 kHz at 48/56/64 Kb/s G.722.1: 7.0 kHz at 24/32 Kb/s (H.323) G.728: 3.4 kHz at 16 Kb/s G.723.1: 3.4 kHz at 5.3/6.3 Kb/s (H.323) G.729: 3.4 kHz at 8 Kb/s (H.323) MPEG-4 AAC (mono) 14 kHz at 64/96 Kb/s (H.323) at 48 Kb/s (H.320)
Echo cancellation	Noise Suppressor included Automatic Gain Control included

Graphics	
XGA	1024 pixels x 768 lines (H.263), with PCSA-DSB1S
4CIF	704 pixels x 576 lines (H.261 Annex D and H.263)

Picture in Picture	
Sub screen size	4.3" (256 x 192), One of four corners (viewable area measured diagonally)

ITU-T Standards (excludes audio/video standards)	
	H.320, H.323 H.221 Bonding H.281 FECC H.225.0 H.239 H.242 H.243 H.245 T.120

Network Protocols	
	TELNET (Server) HTTP (Server) FTP (Server) SNMP (Agent) DNS (Client) DHCP (Client) RTP/RTCP TCP/UDP ARP SIP

Multipoint Capabilities	
	Up to 6 sites (H.320/H.323)** Up to 10 sites (H.320/H.323)***

Lip Synchronization	
	Manual On/Off

Camera Unit	
Image device	1/4 type CCD
Horizontal resolution	NTSC: 470 TV lines, PAL: 460 TV lines
Focal length	F1.8 to 2.9 (3.1 to 31 mm)
Focus	Auto/Manual
IRIS	Auto
Zoom ratio	x10 Optical zoom (x40 with digital zoom)
Pan angle	-100° to +100° (Max. 100°/sec)
Tilt angle	-25° to +25° (Max. 125°/sec)
Preset	Up to 6 positions
S/N	More than 50 dB
Others	Back light compensation Auto white balance

Remote Commander Unit	
Format	Wireless SIRCS
Interfaces (Communication Terminal)	
Video	D-Sub 15-pin Dedicated Camera I/F x1 S-video or Composite input x1 (switchable with conversion connector) S-video output x2 (for main/sub monitor) Composite output (AUX) RGB output
Audio	Line input RCA AUX input RCA (bypass echo cancellor) External analog microphone input, Mini-jack (Plug in power) x2 External digital microphone input x2 Line output RCA x2 (one mixed output)
Network	10Base-T/100Base-TX External ISDN Unit I/F
Control	SIRCS IR Out x2 Wired SIRCS In (Control-S) RS-232C
DSB I/F	Dedicated D-Sub 15
RGB I/F	RGB output
Memory Stick Media	Memory Stick slot
Digital whiteboard	Dedicated connector
Interfaces (Camera Unit)	
Video	IR for DS150
Terminal	Dedicated 23-pin
AUX camera	8-pin Mini-DIN

General	
Operating temperature	5 °C to 35 °C
Operating humidity	30% to 70%
Storage temperature	-20 °C to +55 °C
Storage humidity	25% to 75%
Power Requirements	PCS-G50: AC 120 V, 50/60 Hz, PCS-G50P: AC 220 V to 240 V, 50/60 Hz
Power Consumption	DC 19.5 V, 5 A
Communication Terminal	16 5/8 x 2 5/8 x 10 1/8 inches (420 x 66 x 256 mm), excl. projections
Dimensions (W x H x D)	excl. projections
Camera Unit	5 1/4 x 5 5/8 x 5 1/8 (131 x 141 x 130 mm), excl. projections
Dimensions (W x H x D)	excl. projections
Remote Commander unit	1 7/8 x 1 3/4 x 7 3/4 inches (47 x 43 x 195 mm), excl. projections
Dimensions (W x H x D)	excl. projections
Communication Terminal	10 lbs 2 oz (4.6 kg)
Weight	
Camera Unit	2 lbs 3 oz (1.0 kg)
Weight	
Remote Commander Unit	6.3 oz (180 g), incl. batteries
Weight	

System Components and Supplied Accessories	
	Communication Terminal
	Camera Unit (includes dedicated 3 m camera cable)
	Remote Commander Unit
	AC Adaptor/Power Cord
	Omnidirectional Microphone (PCS-A1)
	IR Repeater x2
	Manganese Battery for Remote Commander x2
	Operation Manual CD-ROM (Japanese, English, French, Spanish, Italian, German, Portuguese, Simplified Chinese)
	Operation Guide
	Quick Connection Guide
	Cable Connection Guide
	Worldwide Warranty Booklet
	Audio Cable (1.0 m)
	S-Video Cable (1.5 m)
	Mini DIN 7-pin to RCA Conversion Connector

* When the H.261 video standard is used, up to 2 Mb/s is supported.

** Requires optional MCU software. IP/ISDN Bridging is possible.

*** Requires optional MCU software. Connections between base units must be IP (H.323). IP/ISDN Bridging is possible.

SONY®

IVCi
180 Adams Avenue
Hauppauge, NY 11788
1-800-224-7083
www.ivci.com

VC-0145
MK10273V1

©2005 Sony Corporation. All rights reserved.
Reproduction in whole or in part without written permission is prohibited.
Features and specifications are subject to change without notice.
All non-metric weights and measurements are approximate.
Sony, IPELA, Memory Stick, Memory Stick PRO, Memory Stick Duo,
Remote Commander, and the Memory Stick logo are trademarks of Sony.
Some images in this brochure are simulated.
QuickTime is a trademark of Apple Computer, Inc.